



CM2002

Loss Factors Methodology and Disclosure

Issue Version Number: 8.0

Data Classification: Public

Published Date: 12/01/2026

©2026 Unison Networks Limited

This is an approved controlled document and is subject to change.

Please ensure you have the most up-to-date copy at all times.

Contact the Document Owner for the latest version.

CM2002 Loss Factors Methodology and Disclosure

Overview

Document purpose This document outlines the methodology for the evaluation, allocation and apportionment of loss factors.

Intended audience This is a public disclosure document, required under industry agreements such as the:

- Electricity Industry Participation Code, and
- Use of System or Default Distributor Agreements.

Document contributors

Contributors	Name and Position Title	Approval Date
Creator	Henk Potgieter Network Analysis and Solutions Engineer Steven Simpson Future Networks and Constraints Engineer	09/01/2026
Authoriser	David Clarkson Innovative Solutions Manager	12/01/2026
Approver	Gaganpreet Chadha General Manager – Networks and Operations	12/01/2026

Key dates **Published Date** 12/01/2026

Recommended renewal period – every 2 years, or earlier if any of the following occur:

- legislative or regulatory changes
- risk reviews
- continuous improvements
- user feedback, or
- audit findings

Related references

Legislation

- Electricity Industry Participation Code 2010

Unison Policy

- CM0001 Pricing Policy and Schedules

Other Reference

- Electricity Authority Guidelines on the Calculation and the Use of the Loss Factors for Reconciliation Purposes 2018

Overview

Content

This document contains the following topics:

Topic	See Page
1. Definitions/Abbreviations	4
2. Introduction	7
3. Unison's Network Disaggregation	8
4. Methodology	11
Appendix A – Loss Factors	15
Appendix B – Summary of Document Changes	16

1. Definitions/Abbreviations

Code For the purposes of this document refers to the Electricity Industry Participation Code 2010.

EA Guidelines For the purpose of this document refers to the guidelines on the calculation and use of loss factors for reconciliation purposes, published by the Electricity Authority in June 2018.

EMS Energy Market Services – a commercial business group of Transpower that provides metering services at Grid Exit Points (GXP). It monitors electricity flows and power quality at national grid connections to distribution networks and industrial sites.

GR250 GR250 Distributor Report – Electricity Traded – is the report defined in the Registry Functional Specification that details:

- loss-adjusted half-hour generation information, and
- ICP days (scaled loss-adjusted UFE inclusive balanced half-hour consumption).

Grid The National Grid is the network of high-voltage power lines operated by Transpower.

GXP Grid Exit Point – any point of connection between Transpower’s transmission system and the distributor’s network.

LF Loss Factor – a ratio expressed as a decimal number. It is used as a multiplier to be applied to the volume of energy measured at a Point of Connection (POC) within a network study area. This multiplier is used to scale the volume to account for the attributed technical or reconciliation loss relevant to that POC.

Load loss The loss of electricity, primarily in the form of heat, as:

- electricity is injected or consumed from the network, and
- current flows through network components which have electrical resistance.

Loss code Distributors are required by the Code to assign every point of connection a loss code and associated loss factors.

Definitions/Abbreviations

No load loss The electricity loss arising from the energy consumption necessary to energise the:

- zone substation
 - distribution transformers
 - voltage regulators
 - auto transformers, and
 - isolating transformers.
-

NSP Network Supply Point – the point of connection at which a supply of electricity may flow between the distribution network and the embedded generators.

NTLF Non-Technical Loss Factor – a ratio expressed as a decimal number that represents electrical losses arising from inaccuracies in measurement and data handling processes. These can arise from:

- metering and meter reading errors
- inaccurate metering installations
- theft, and/or
- unread meters.

It is calculated as the difference between Reconciliation Loss (RL) and Technical Loss (TL).

POC Point of Connection – the point where electricity may flow between the network and the consumer's installation and to which an ICP is allocated.

PowerFactory DlgSILENT PowerFactory – a software package that supports electricity load flow and contingency analysis.

Reconciliation Manager The electricity market service provider who is for the time being appointed as the Reconciliation Manager.

Retailer An Electricity Retailer – the company that supplies electricity to consumers with installations connected to the distributor's network.

Definitions/Abbreviations

RL Reconciliation Loss – the difference, (as reported by traders to the Reconciliation Manager) between energy:

- injected into the network study area, and
 - delivered to the points of connection within that network study area.
-

RLF Reconciliation Loss Factor – the multiplier to be applied to the volume of energy measured at a Point of Connection (POC) within a network study area. This is used to scale the volume to account for the attributed Reconciliation Loss (RL) relevant to that POC.

SCADA Supervisory Control and Data Acquisition – a system that operates with coded signals over the Unison fibre network to provide control of remote equipment. SCADA allows Unison’s entire electrical network to be monitored and operated from Unison’s Network Operations Centre.

TL Technical Loss – a loss resulting from load losses and no load losses between the parent Network Supply Point (NSP) and the Point of Connection (POC). Technical losses in the context of this document are calculated through network simulation.

TLF Technical Loss Factor – a multiplier to be applied to the electricity delivered or injected at a Point of Connection (POC) within a network study area to scale the volume to account for attributed Technical Loss (TL) between that POC and the parent Network Supply Point (NSP).

UFE Unaccounted for Electricity – calculated from the difference between:

- reported energy injected into a network, and
- the reported energy extracted from the network after it has been adjusted for losses.

2. Introduction

2.1 Background

As electricity travels through an electrical network, a portion is lost due to a variety of factors. These can include electrical energy converted to heat due to network internal resistance. Electricity losses influence the cost of electricity for all consumers and are apportioned to consumers based on the calculation of loss code loss factors.

The Electricity Participation Code 2010 requires Unison to publish its loss codes and associated loss factors. This ensures that:

- pricing remains transparent to all consumers, and
 - Unison is committed to minimising such losses.
-

2.2 Losses

Losses on an electrical network can be categorised as follows:

- Technical losses which include:
 - load losses – these vary with the amount of electricity distributed. These losses arise from the heating effects due to resistance in network assets, and
 - no load losses – these are not affected by the magnitude of current. These losses take the form of heat and noise and occur while transformers or zone substations are energised.
 - Non-technical losses such as:
 - theft
 - metering inaccuracies, and
 - data handling errors.
 - Reconciliation losses – the combination of technical and non-technical losses, and
 - Unaccounted for Electricity (UFE) – the calculated difference between:
 - reported energy injected into the network, and
 - reported energy extracted from the network after it has been adjusted for losses.
-

3. Unison's Network Disaggregation

3.1 Unison's network

Figure 1 shows the typical structure of Unison's network with points of energy metering shown for various consumers. From this figure the points of metering are also the points of connection (POC).

The connection points for some low voltage (LV) consumers occur downstream after non-Unison-owned LV conductors. These conductors are classed as service mains and the losses incurred along these are accounted for in the loss evaluation.

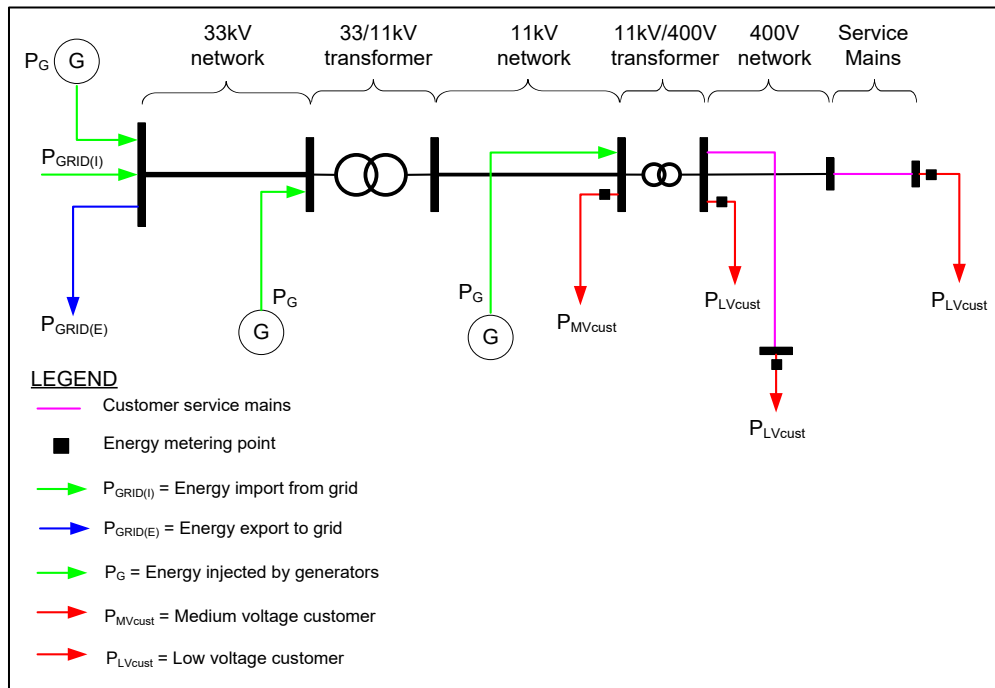

Figure 1 – Typical Structure of Unison's Distribution Network

3.2 Method

Unison separates its network into network study areas and network segments, as recommended in the Electricity Authority Guidelines on the calculation and use of loss factors for reconciliation purposes (EA Guidelines).

3.2.1 Network Study Areas

Unison has two network study areas, representing two groups of Grid Exit Points (GXP) servicing two distinct areas. Table 1 summarises these network study areas and their corresponding GXPs.

Network Study Area	GXP	Identifier
Hawke's Bay (incl. Napier and Hastings)	33kV Fernhill	FHL0331
	33kV Redclyffe	RDF0331
	33kV Whakatu	WTU0331
Central Region (incl. Rotorua and Taupo)	33kV Rotorua	ROT0331
	11kV Rotorua	ROT0111
	33kV Wairakei	WRK0331
	11kV Tarukenga	TRK0111
	11kV Atiamuri	ATI0112
	11kV Owkata	OWH0111
	33kV Tauhara	TAB0331

Table 1 – Network Study Areas and Identifiers

3.2.2 Network Segments

Each network study area is divided into three network segments (as shown in Table 2) representing the three levels of voltage reticulation on Unison's network.

Network Segment	Included for Loss Allocation Purposes
33kV Network	<ul style="list-style-type: none"> • 33kV lines and cables • 33kV switches
11kV Network	<ul style="list-style-type: none"> • 11kV lines and cables • 11kV switches • Load and no-load loss of the 33/11kV zone substation transformers
LV (400V) Network	<ul style="list-style-type: none"> • LV network representation • LV switches • Load and no load loss of the 11kV/LV distribution transformers

Table 2 – Network Segments

3.3 Loss codes and factors

Loss codes are created for each connection point on the network based on the:

- network region
- network segment it belongs to (voltage-level it connects to)
- type of connection (load or/and generation), and
- size of the connection.

A loss factor (LF) is calculated for each loss code based on the losses allocated to each loss code.

Site specific studies, with dedicated loss codes are completed for:

- embedded generating stations with a nameplate capacity of 10MW or more
- interconnection points with other electricity distributors, and
- distinct consumer connections (at Unison's discretion) for the purpose of losses allocation.

Unison's loss codes, including their description and loss factors for consumption and generation are provided in *Appendix A – Loss Factors*.

4. Methodology

4.1 Overview of approach

The purpose of this methodology is to:

- ensure compliance with the Code
 - ensure Unison meets its obligations under the Use of System and/or Default Distributor Agreements
 - account for losses on the Unison network, and
 - enable Unison to allocate losses to loss codes in a robust, consistent and fair manner.
-

4.2 Loss calculation

4.2.1 Reconciliation Loss (RL)

Reconciliation losses are calculated for network study areas by combining the data recorded at the GXP and reported via the:

- Energy Market Services (EMS), and
- GR250 Distributor Report – Electricity Traded file (supplied by the Reconciliation Manager).

The GR250 data is converted to pre-loss values using the reported loss codes and defined reconciliation loss factors (RLFs) for the period.

$$GR250_{PreLoss} = GR250_{IncludingLoss} / RLF$$

The reconciliation losses are calculated as follows:

$$RL = |EMS_x| + |GR250_I| - |EMS_I| - |GR250_x|$$

where:	EMS_I	=	the absolute value of the EMS kWh values marked as Injected
	EMS_x	=	the absolute value of the EMS kWh values marked as Exit
	$GR250_I$	=	the absolute value of the pre-loss GR250 kWh values marked as Injected
	$GR250_x$	=	the absolute value of the GR250 kWh values marked as Exit

4.2 Loss Calculation (cont)

4.2.2 Technical Loss (TL)

The network study area and network segment technical losses are calculated through the:

- simulation of Unison's network for normal network configuration under peak load
- identification of annual peak loads from Unison's SCADA data
- identification of losses introduced by generation through the incremental method defined in the EA Guidelines, and
- application of load loss factors, as calculated from Unison's SCADA data.

Accuracy factors include:

- allocation of load in the network model
- load diversity allocation
- limited SCADA data
- completeness of network models
- use of the incremental method for generators, and
- the use of typical impedances in network models.

4.2.3 Non-Technical Loss (NTL)

Non-technical losses are the difference between the reconciliation losses and technical losses allocated and expressed as:

$$NTL = RL - TL$$

4.3 Loss apportionment

Losses are allocated so the equation below remains true:

$$RL_{Study\ Area} = \sum_{n=1}^k (LRLF_n - 1) \cdot LE_n - \sum_{n=1}^k (GRLF_n - 1) \cdot GE_n$$

- where:
- RL_{Study Area} = Reconciliation Loss of Study Area
 - LRLF_n = Reconciliation Loss Factor of Loss Category Code n when consuming energy from the grid
 - LE_n = Energy consumed by Loss Category Code n over the period
 - GRLF_n = Reconciliation Loss Factor of Loss Category Code n when supplying energy to the grid
 - GE_n = Energy supplied by Loss Category Code n over the period
 - k = Number of Loss Category Codes

4.3.1 Technical Loss

Technical losses are apportioned to loss codes using one of the following methods:

- Pro-rata method – based on peak demand for consumption Loss Factor calculations
- Incremental method – based on low, medium and high load and generation scenarios for generation Loss Factor calculations, or
- I²R calculation – for a dedicated point to point connection for either consumption or generation Loss Factor calculations.

4.3.2 Reconciliation Loss

Reconciliation losses are apportioned so the ratio of the loss code technical losses to the study area technical losses

is equal to

the ratio of the loss code reconciliation losses to the study area reconciliation losses.

This is expressed in the equation below.

$$\begin{aligned} & \text{(Loss Code allocated TL/Network Study Area TL)} \\ & = \text{(Loss Code allocated RL/Network Study Area RL)} \end{aligned}$$

**4.4 Loss
factor
calculation**

Loss factors for loss codes are calculated using the equation expressed below:

$$LF = \frac{(Volume Consumed or Generated [kWh] + Allocated Loss [kWh])}{(Volume Consumed or Generated [kWh])}$$

Where a consumption loss factor greater than one represents an increase in network losses, and a generation loss factor of greater than one represents a decrease in network losses.

Appendix A – Loss Factors

Loss factors Table 3 outlines the individual TLF, NTLF and RLF for the information disclosure.

Loss Code	Description	Energy Type	TLF	NTLF	RLF
H3H	MV metered customer– Hawke’s Bay	Load	1.0178	1.0094	1.0272
H3L	LV metered customer supplied by the LV distribution network – Hawke’s Bay	Load	1.0413	1.0218	1.0631
H3M	LV metered customer supplied by a dedicated distribution transformer– Hawke’s Bay	Load	1.0302	1.0159	1.0461
RKTPO	Rotokawa	Generate	0.9830	0.9953	0.9784
CBTPO	Te Huka 1 & 2 Binary Plant	Generate	0.9964	0.9990	0.9954
CBTPO	Te Huka 1 & 2 Binary Plant	Load	0.9964	0.9990	0.9954
R3N	Hinemaiaia A, B and C	Generate	1.0111	1.0030	1.0141
R3H	MV metered customer – Central Region	Load	1.0152	1.0042	1.0193
R3I	Fonterra	Load	1.0172	1.0047	1.0219
R3L	LV metered customer supplied by the LV distribution network – Central Region	Load	1.0361	1.0099	1.0460
R3M	LV metered customer supplied by a dedicated distribution transformer – Central Region	Load	1.0230	1.0063	1.0293
THTPO	Te Huka 3 Plant	Generate	0.9813	0.9949	0.9761
THTPO	Te Huka 3 Plant	Load	1	1	1
FLTPO	Fletchers Taupo East	Generate	1.0000	1.0000	1.0000
FLTPO	Fletchers Taupo East	Load	1.0081	1.0081	1.0081

Table 3 – Unison’s Submission Loss Factors

Appendix B – Summary of Document Changes

Date	Version No.	Changes to Document	Creator	Authoriser	Approver
20/06/2007	1.0	New Standard	Jiak-San Tan, Don Whitfield	Commercial Manager	GM Networks & Operations
25/01/2013	2.0	<p>Full review and update into new template.</p> <p>Major change to the calculation methodology by:</p> <ul style="list-style-type: none"> replacing PSSA modelling with PowerFactory modelling, and aligning with the new EA Guidelines. <p>Document assigned to Network group but still retains original document number.</p>	Network Analysis Engineer	Network Strategy and Investment Manager	General Manager Networks and Operations
21/12/2016	3.0	Under the 2016 review of Network documents it was approved by the Asset Manager that last year's values will be used for this year. The system loss calculations will be rolled over till next year and the document reviewed in 01/10/2017.	Technical Planning Technical Lead	Network Development Manager	General Manager Networks and Operations
09/11/2017	4.0	Full review. Document rolled over. No changes made.	Energy Solutions Manager	Energy Solutions Manager	General Manager Networks and Operations
26/11/2020	5.0	<p>Full review.</p> <p>Addition of submission loss factors.</p> <p>Methodology updated to align with EA Guidelines.</p> <p>Document name changed from System Loss Allocation. Related spreadsheet archived and information included in document.</p>	Network Analysis and Solutions Engineer	Energy Solutions Manager	General Manager Networks and Operations
17/12/2021	6.0	<p>Full review.</p> <p>No changes made as information is still current.</p>	Network Analysis and Solutions Engineer	Energy Solutions Manager	General Manager Networks and Operations

Date	Version No.	Changes to Document	Creator	Authoriser	Approver
30/01/2023	7.0	Full Review	Network Analysis Solutions Engineer and	Commercial Manager	Chief Operating Officer
29/01/2024	7.1	Minor Review No changes	Network Analysis Solutions Engineer and	Network Analysis and Solutions Team Lead	Network and Operations GM
12/01/2026	8.0	Full Review New Calculations for 2026 added in Appendix A	Network Analysis Solutions Engineer and	Innovative Solutions Manager	Network and Operations GM